

**Model: OFC4**

## ***OWNERS MANUAL***



### **INSTRUCTIONS**

This manual contains important information concerning the installation and operation of the crushers listed above.  
**Read manual thoroughly and keep for future reference**

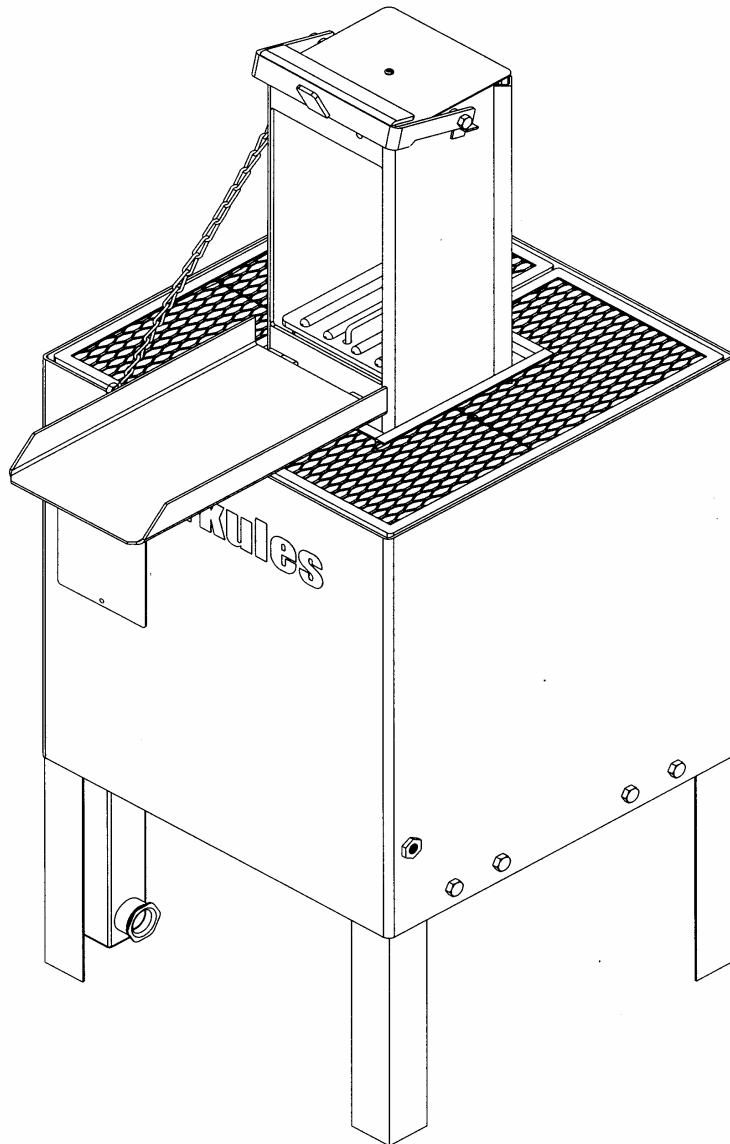

Herkules Equipment Corporation  
248-960-7100

website: [www.herkules.us](http://www.herkules.us)

2760 Ridgeway Court  
800-444-4351

e-mail: [info@herkules.us](mailto:info@herkules.us)

Walled Lake, MI 48390-1662 USA  
Fax 248 960-7109

# Table of Contents

Warnings .....	2
Model Information (List of models with descriptions and data) .....	3
Installation .....	4
Inspection .....	5
Operation .....	5
Cleaning .....	6
Maintenance .....	7
Repair .....	7
Drawings with part lists: .....	7-8

## Warning Symbol



This symbol alerts you to the possibility of serious injury or death if you do not follow the instructions.

## Caution Symbol



This symbol alerts you to the possibility of damage to or destruction of equipment if you do not follow the instructions.

# WARNING

## FAILURE TO HEED THE FOLLOWING WARNINGS MAY RESULT IN PERSONAL INJURY AND/OR PROPERTY DAMAGE.

- 1 Herkules will not be held responsible for any personal injury and/or property damaged caused due to owner/operator failure to follow the warnings and cautions listed in this manual.
- 2 Read and understand all warnings, cautions and instructions before operating this equipment.
- 3 It is the owner/operators responsibility to maintain the legibility of all warning and instruction labels.
- 4 Do not alter or modify any part of this equipment.
- 5 Do not attempt to bypass the door/latch interlock system. The door interlock is provided for operator safety.
- 6 DO NOT open the door while the unit is operating. Always wait for the crusher to cycle completely.
- 7 Crush only intended matter for the crusher.
- 8 Always wear safety glasses when operating the crusher.
- 9 Always wear suitable industrial gloves when handling crushed objects to prevent injury.
- 10 Check equipment regularly for proper operation and repair or replace worn or damaged parts immediately.
- 11 Any crusher that appears to be damaged in any way, is badly worn or operates abnormally shall be removed from use until repairs are made. Use only manufacture's approved accessories and service parts. Contact a factory authorized service center for repairs.
- 12 DO NOT REMOVE THIS LABEL. REPLACE IF DAMAGED.

# Model Information

## SPECIFICATIONS

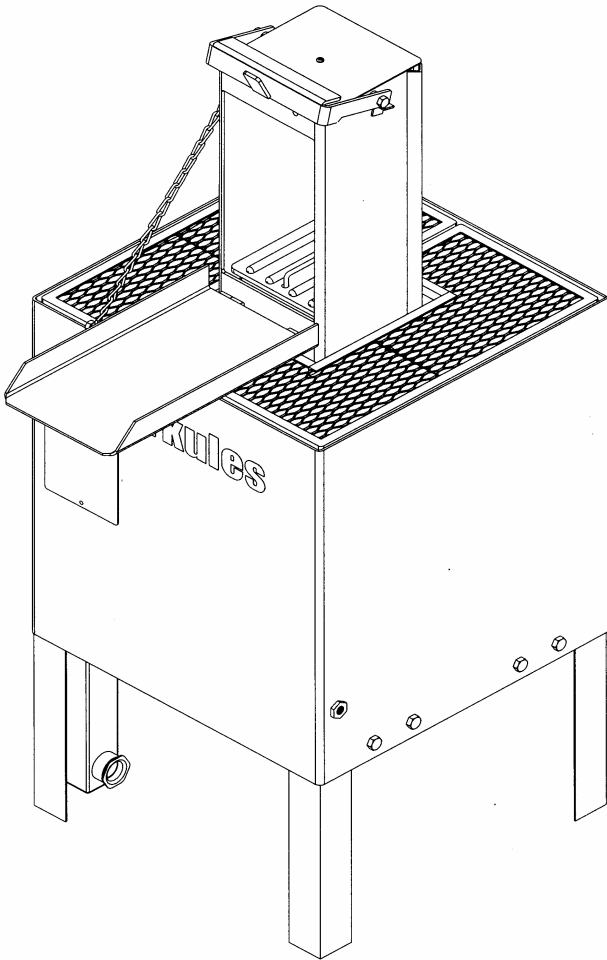

Maximum crushing pressure	35,000 lbs.
Filter capacity	One heavy duty filter or four auto filters
Filter type	Heavy duty
Filter crush	Up to 80%
Residual oil removed from crushed filter	95 - 98%
Time to crush filter	35 - 55 seconds

Overall width	27-1/2"
Overall height	66"
Overall depth	27-1/2"

Chamber width	9"
Chamber height	20-1/8"
Chamber depth	9"

Required air pressure	100-120 p.s.i.
Required air flow	44 cfm

Total weight	640 lbs.
--------------	----------

### Filter Specifications:

- 8" maximum filter diameter (single)
- 15-3/4" maximum height with spacer in place
- 18-3/4" maximum height with spacer removed

## DESCRIPTION

Model OFC4 crusher is capable of crushing four filters at one time or one large heavy duty oil filter. The crusher is designed for automotive and light truck shops to crush and dispose of used oil filters in an environmentally correct manner. The crusher provides the following features:

- Powerful 17.5 ton air bag crushing plate technology assures the force necessary to do the job when crushing four filters.
- Operates with external air only. No electric power is required.
- Safe double lock door protects operator.
- Removes 95-98% of residual oil from oil filter.
- Easy connection for oil drain off.
- Four oil filter capacity.

## OWNER/OPERATOR RESPONSIBILITY

It is the owner/operator responsibility to properly use and maintain this equipment.

The instructions and warnings contained in this manual shall be read and understood by the owner/operator prior to operating this equipment.

If an owner/operator does not understand English, the contents of this manual shall be explained in the owner/operator native language to assure the owner/operator comprehends.

It is the owner/operator responsibility to maintain the legibility of all warning and Instruction labels.

The owner/operator shall retain this manual for future reference to Important warnings, operating and maintenance instructions.

Figure 1

## INSTALLATION

Installation consists of anchoring the unit to the floor, connecting an external air supply with 100 to 120 p.s.i. and routing the waste oil drain to a suitable waste oil reservoir.

DO NOT attempt to operate the unit while on a skid. The initial crush of the oil filter(s) will cause the unit to move or jump if not secured properly. The crusher must be anchored to the floor before operating. The unit is equipped with a 125 p.s.i. relief valve that will bleed off air if the unit is inadvertently connected to an air source greater than 125 p.s.i.

Install the crusher as follows (See Figure 1).

- A. Anchor the unit to the floor using 1/2" diameter hardware.
- B. Connect the supplied pressure regulator/filter to the crusher 3/8" NPT air inlet fitting.
- C. Connect the external air supply to the pressure regulator/filter.
- D. Place a waste oil collection receptacle underneath the waste oil port.

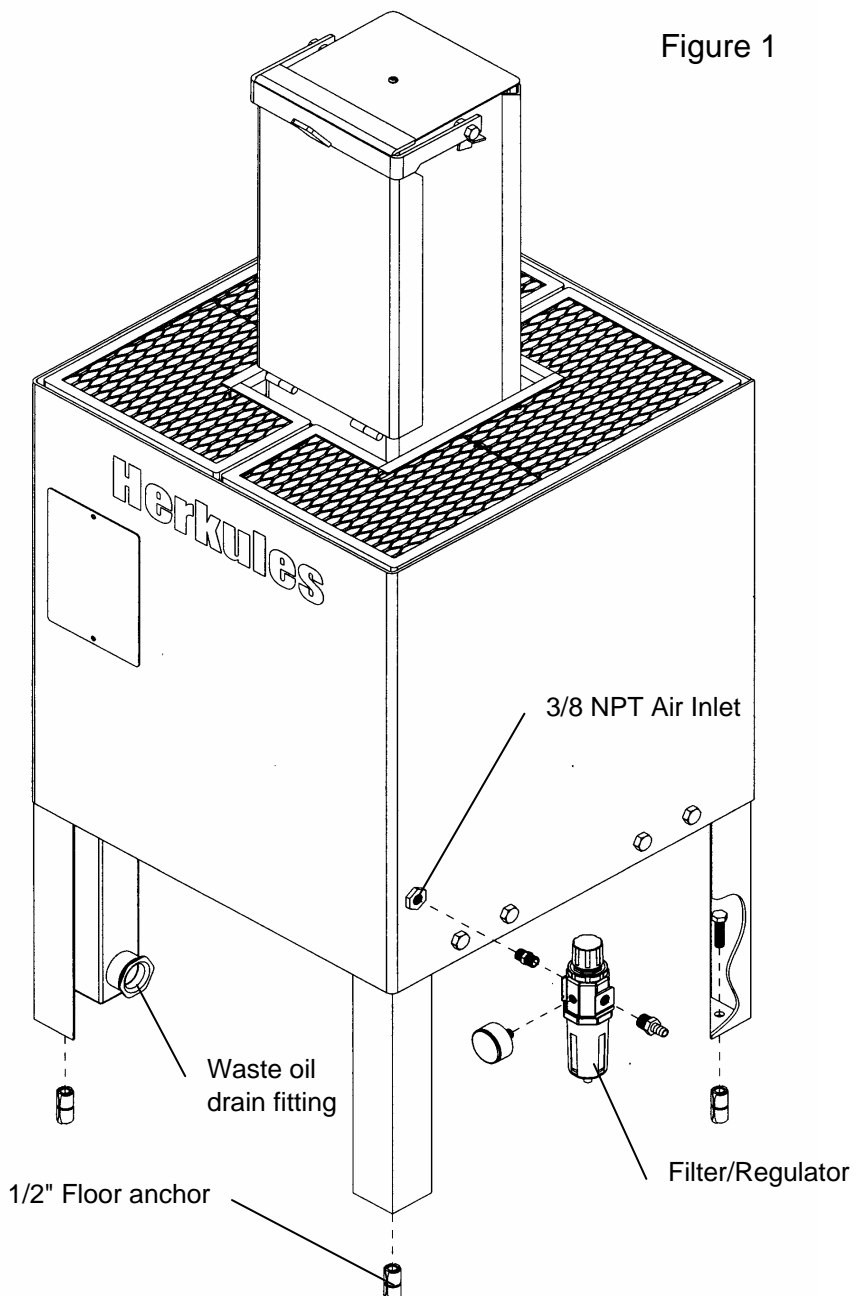

## INSPECTION

Prior to operation a visual Inspection shall be made. Check crusher for leaks, worn or missing parts.

Any crusher that appears to be damaged in any way, is badly worn or operates abnormally shall be removed from use until repairs are made. Contact a factory authorized service center for repairs.

If over pressurizing of the equipment is believed to have occurred, contact a factory authorized service center for inspection of the crusher.

An annual inspection by a factory authorized service center is recommended.

## OPERATION

Turn the external air supply on.

Verify the pressure gauge on the pressure regulator/filter reads between 100 and 120 p.s.i. Adjust the regulator as required.

### NOTE:

If the external air supply is less than 100 p.s.i., the crusher will operate but the crushing performance is reduced.

Lift the door latch and pull the door down to gain access to the crushing chamber.

Place the oil filter(s) to be crushed gasket side down on the bottom of the crushing chamber. Arrange the filters as follows:

Quantity & Type	Position
(1) Heavy duty truck filter	Center of ram plate
(1) Auto filter	Center of ram plate
(2) Auto filters	Opposite corners
(3) Auto filters	(2) in back corners and (1) in front center
(4) Auto filters	(2) in back corners and (2) in front corners

For filters over 15-3/4" in height, remove bottom spacer.

Close the door and pull the door latch down securely. The crusher will operate for approximately 55 seconds with an audible air sound.

Wait until the air flow stops.

### **WARNING**

The crushing mandrel may be still moving when the door is opened. Wait until the mandrel stops before placing hand in chamber.

### **WARNING**

A crushed oil filter may have jagged metal edges. Use good industrial work gloves to protect the hands when removing a crushed oil filter.

Lift door latch and open door.

Remove the crushed oil filter and dispose of it in an environmentally correct manner.

## CLEANING INSTRUCTIONS

User should perform cleaning procedure on a regular basis (See Figure 2).

### CAUTION

Clean crusher immediately if piston fails to retract.  
Failure to clean may damage crusher.

### WARNING

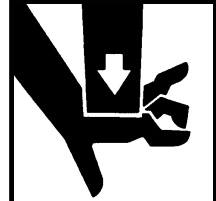

Disconnect Air  
Supply Before  
Cleaning

## CLEANING PROCEDURE

- A. Empty crush chamber and disconnect air.
- B. Remove cleanout panel and clean sludge from drain pan.
- C. Replace cleanout panel and reconnect air supply.
- D. Cycle crusher and allow piston to fully extend.
- E. Insert retaining pin into hole to lock piston in place.
- F. Disconnect air supply and fully exhaust air bag.
- G. Hold waste oil reservoir to prevent spill and remove mounting bolts.
- H. Remove waste oil reservoir and dispose of contents according to applicable environmental regulations.
- I. Remove cleanout plug from waste oil reservoir.
- J. Scrape sludge from bottom of waste oil reservoir.
- K. Replace clean out plug and install waste oil reservoir.
- L. Reconnect air supply and cycle machine to remove pin.

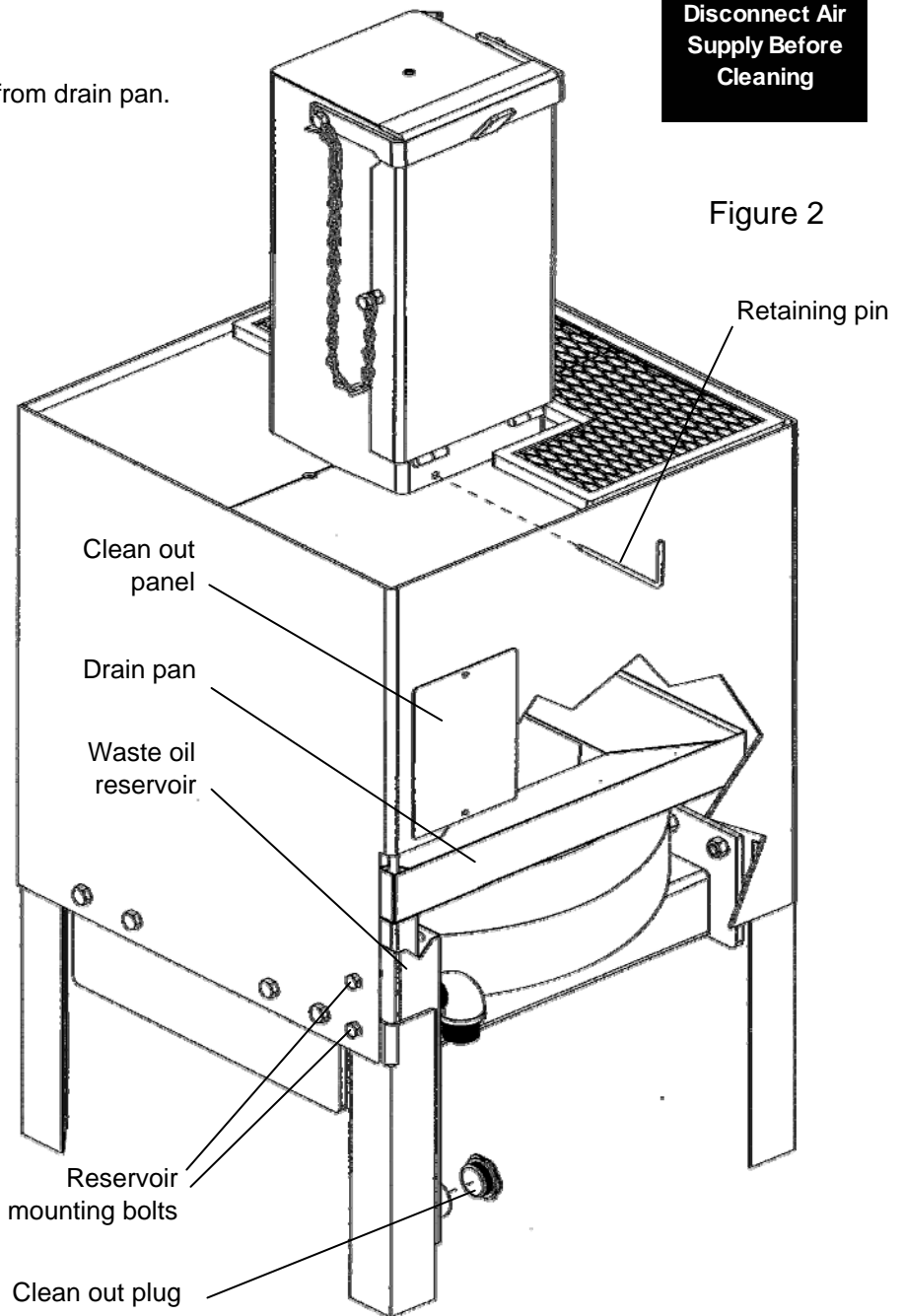

Figure 2

## SAFETY INFORMATION

Read and understand all warnings, cautions and instructions before operating this equipment. Caution should be used when operating this equipment as personal injury and/or property damage can result from equipment misuse. Adequate personal protection is recommended to prevent splashing of oil on the skin or in the eyes.

## MAINTENANCE

Regularly check the pressure filter/regulator moisture trap for water. Drain as required.

Regularly check the waste oil drain line system to prevent oil backing up in the crusher chamber. and causing an oil spill. Clean, repair, adjust as required.

Regularly clean the crusher chamber to remove any accumulated oil sludge, metal particles or any other debris that could affect the crusher operation or block the waste oil drain system.

Apply grease to door hinges on a regular basis to prevent the door from binding.

Apply motor oil to door latch pivot points on a regular basis to prevent latch from binding.

## REPAIR

No service parts are available for this oil filter crusher. Special tools and procedures are required for repair. If repair is required, contact Herkules Equipment Corporation Customer Service, (800-444-4351) for your nearest authorized service center.

## SERVICE PARTS

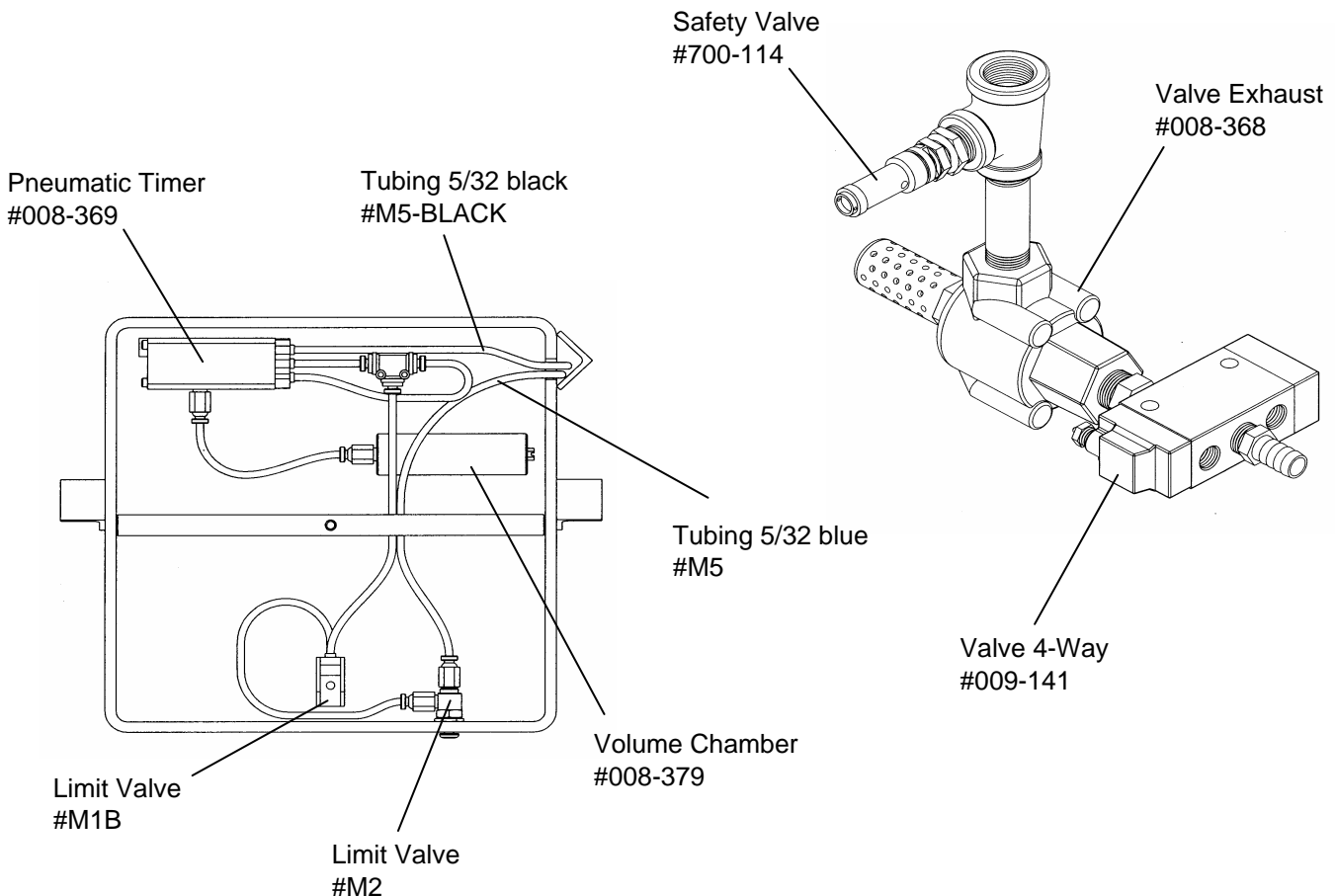

**SERVICE PARTS**

