



Model: AFC2

OWNERS MANUAL



INSTRUCTIONS

This manual contains important information concerning the installation and operation of the crusher listed above.
Read manual thoroughly and keep for future reference

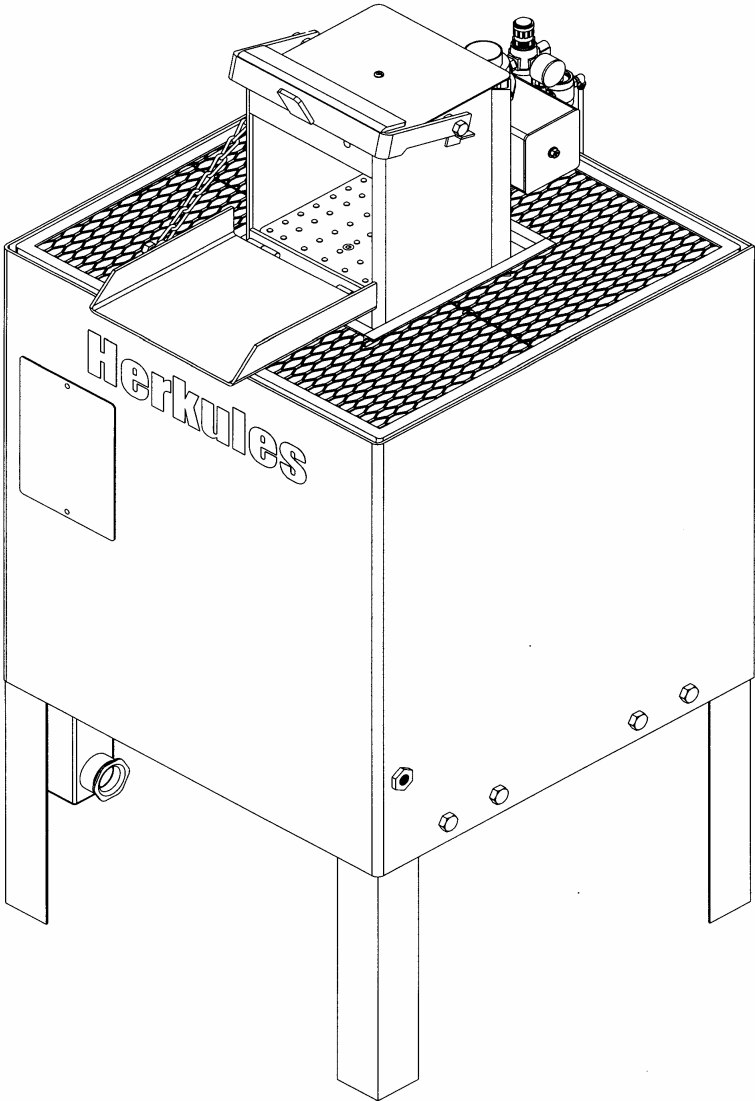

Herkules Equipment Corporation
248-960-7100
website: www.herkules.us

2760 Ridgeway Court
800-444-4351

Walled Lake, MI 48390-1662 USA
Fax 248 960-7109

e-mail: info@herkules.us

Table of Contents

Warnings	3
Model Information (List of models with descriptions and data)	4
Installation	5
Inspection	6
Operation	6
Maintenance	7
Repair	7
Drawings with part lists:	7-8

Warning Symbol



This symbol alerts you to the possibility of serious injury or death if you do not follow the instructions.

Caution Symbol



This symbol alerts you to the possibility of damage to or destruction of equipment if you do not follow the instructions.

Serial Number _____

Model Number _____

Purchase Date _____

Distributor _____



WARNING

FAILURE TO HEED THE FOLLOWING WARNINGS MAY RESULT IN PERSONAL INJURY AND/OR PROPERTY DAMAGE.

- 1 Herkules will not be held responsible for any personal injury and/or property damaged caused due to owner/operator failure to follow the warnings and cautions listed in this manual.
- 2 Read and understand all warnings, cautions and instructions before operating this equipment.
- 3 It is the owner/operators responsibility to maintain the legibility of all warning and instruction labels.
- 4 Do not alter or modify any part of this equipment.
- 5 Do not attempt to bypass the door/latch interlock system. The door interlock is provided for operator safety.
- 6 DO NOT open the door while the unit is operating. Always wait for the crusher to cycle completely.
- 7 Crush only intended matter for the crusher.
- 8 Always wear safety glasses when operating the crusher.
- 9 Always wear suitable industrial gloves when handling crushed objects to prevent injury.
- 10 Check equipment regularly for proper operation and repair or replace worn or damaged parts immediately.
- 11 Any crusher that appears to be damaged in any way, is badly worn or operates abnormally shall be removed from use until repairs are made. Use only manufacture's approved accessories and service parts. Contact a factory authorized service center for repairs.
- 12 DO NOT REMOVE THIS LABEL. REPLACE IF DAMAGED.

Model Information

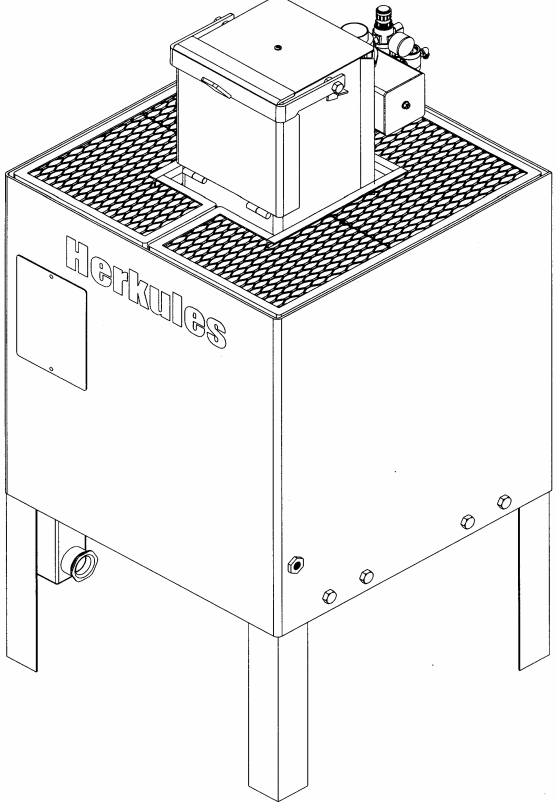
SPECIFICATIONS		
	Maximum crushing pressure	30,000 lbs.
	Can capacity	Two cans
	can crush	Up to 80%
	Residual liquid removed from crushed can	95 - 98%
	Time to crush can	55 seconds
	Overall width	27-1/2"
	Overall height	55"
	Overall depth	27-1/2"
	Chamber width	9"
	Chamber height	8-7/8"
Chamber depth	9"	
Required air pressure	100-120 p.s.i.	
Total weight	550 lbs.	

DESCRIPTION

Model AFC2 crusher is capable of crushing two aerosol cans at one time. The crusher is designed for automotive shops to crush and dispose of used aerosol cans in an environmentally correct manner. The crusher provides the following features:

- Powerful 15 ton air bag crushing plate technology assures the force necessary to do the job when crushing two cans.
- Operates with external air only. No electric power is required.
- Safe double lock door protects operator.
- Removes 95-98% of residual liquid from can.
- Easy connection for liquid drain off.

OWNER/OPERATOR RESPONSIBILITY

It is the responsibility of the owner/operator to properly use and maintain this equipment.

The instructions and warnings contained in this manual shall be read and understood by the owner/operator prior to operating this equipment.

If an owner/operator does not understand English, the contents of this manual shall be explained in the owner/operator native language to assure the owner/operator comprehends.

It is the responsibility of the owner/operator to maintain the legibility of all warning and Instruction labels.

The owner/operator shall retain this manual for future reference to Important warnings, operating and maintenance instructions.

INSTALLATION

Installation consists of anchoring the unit to the floor, connecting an external air supply with 100 to 120 p.s.i., routing the liquid waste drain to a suitable liquid waste reservoir and connecting a 2" id exhaust hose to the fume extractor.

DO NOT attempt to operate the unit while on a skid. The initial crush of the can will cause the unit to move or jump if not secured properly. The crusher must be anchored to the floor before operating. The unit is equipped with a 125 p.s.i. relief valve that will bleed off air if the unit is inadvertently connected to an air source greater than 125 p.s.i.

See Figure (1). Install the crusher as follows.

- A. Anchor the unit to the floor using 1/2" diameter hardware.
- B. Connect the supplied pressure regulator/filter to the crusher 3/8" NPT air inlet fitting.
- C. Connect the external air supply to the pressure regulator/filter.
- D. Connect the liquid waste drain line to the crushers 1-1/2' NPT liquid waste drain fitting.
- E. Connect 2" ID exhaust hose to fume extractor located on the back of the

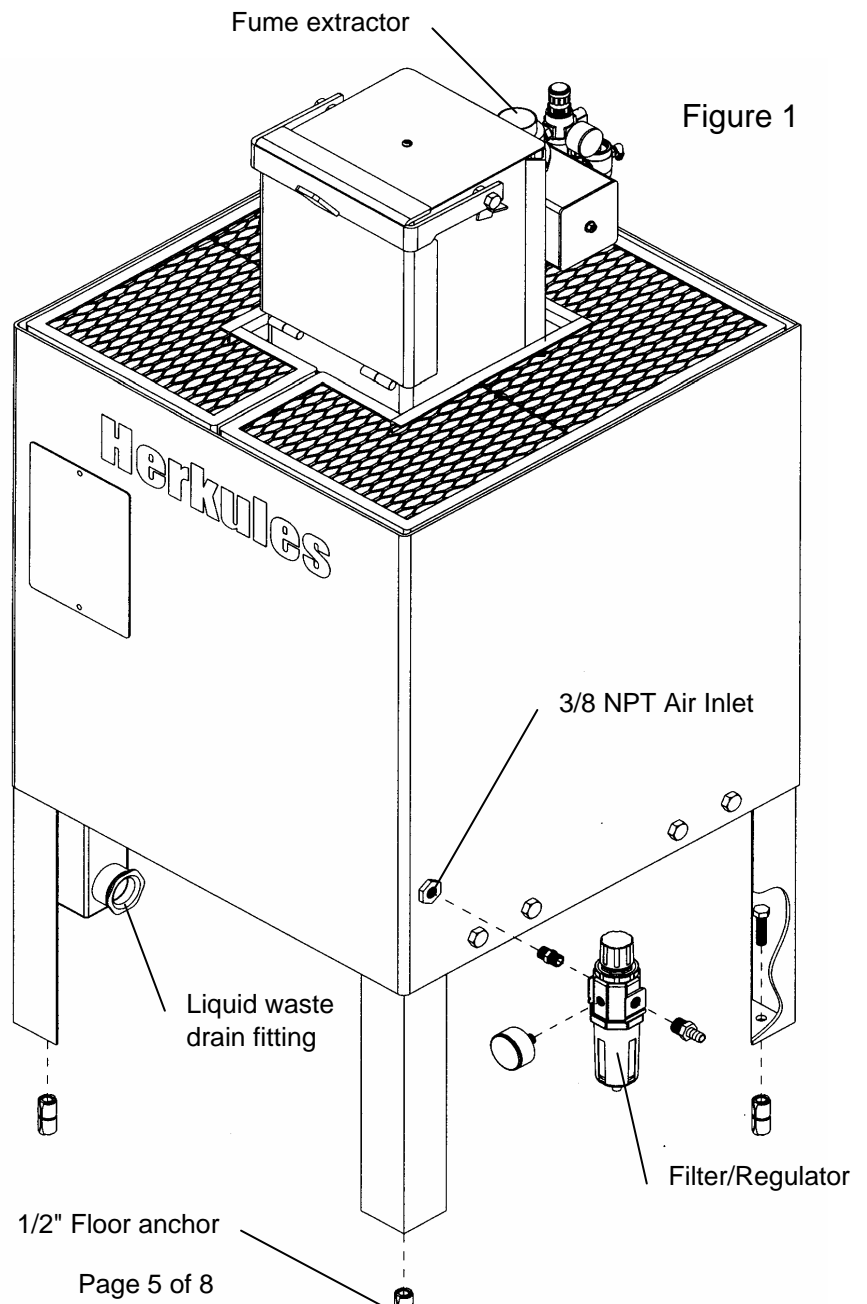

crushing chamber.



INSPECTION

Prior to operation, a visual Inspection shall be made. Check crusher for leaks, worn or missing parts.

Any crusher that appears to be damaged in any way, is badly worn or operates abnormally shall be removed from use until repairs are made. Contact a factory authorized service center for repairs.

If over pressurizing of the equipment is believed to have occurred, contact a factory authorized service center for inspection of the crusher.

An annual inspection by a factory authorized service center is recommended.

OPERATION

Turn the external air supply on.

Verify the pressure gauge on the pressure regulator/filter reads between 100 and 120 p.s.i. Adjust the regulator as required.

NOTE:

If the external air supply is less than 100 p.s.i., the crusher will operate but the crushing performance is reduced.

Lift the door latch and pull the door down to gain access to the crushing chamber.

Place one or two cans (without caps) horizontally in the crushing chamber.

NOTE:

Can(s) should be centered in chamber.

Close the door and pull the door latch down securely. The crusher will operate for approximately 55 seconds with an audible air sound.

Wait until the air flow stops.

WARNING

The crushing mandrel may be still moving when the door is opened. Wait until the mandrel stops before placing hand in chamber.

Lift door latch and open door.

WARNING

A crushed can may have jagged metal edges. Use good industrial work gloves to protect the hands when removing a crushed aerosol can.

Remove the crushed aerosol can and dispose of it in an environmentally correct manner.

SAFETY INFORMATION

Read and understand all warnings, cautions and instructions before operating this equipment. Caution should be used when operating this equipment as personal injury and/or property damage can result from equipment misuse. Adequate personal protection is recommended to prevent splashing of oil on the skin or in the eyes.

MAINTENANCE

Regularly check the pressure filter/regulator moisture trap for water. Drain as required.

Regularly check the waste oil drain line system to prevent liquid backing up in the crusher chamber. and causing an liquid spill. Clean, repair, adjust as required.

Regularly clean the crusher chamber to remove any accumulated sludge, metal particles or any other debris that could affect the crusher operation or block the waste drain system.

Apply grease to door hinges on a regular basis to prevent the door from binding.

Apply motor oil to door latch pivot points on a regular basis to prevent latch from binding.

REPAIR

No service parts are available for this aerosol can crusher. Special tools and procedures are required for repair. If repair is required, contact Herkules Equipment Corporation Customer Service, (800-444-4351) for your nearest authorized service center.

SERVICE PARTS

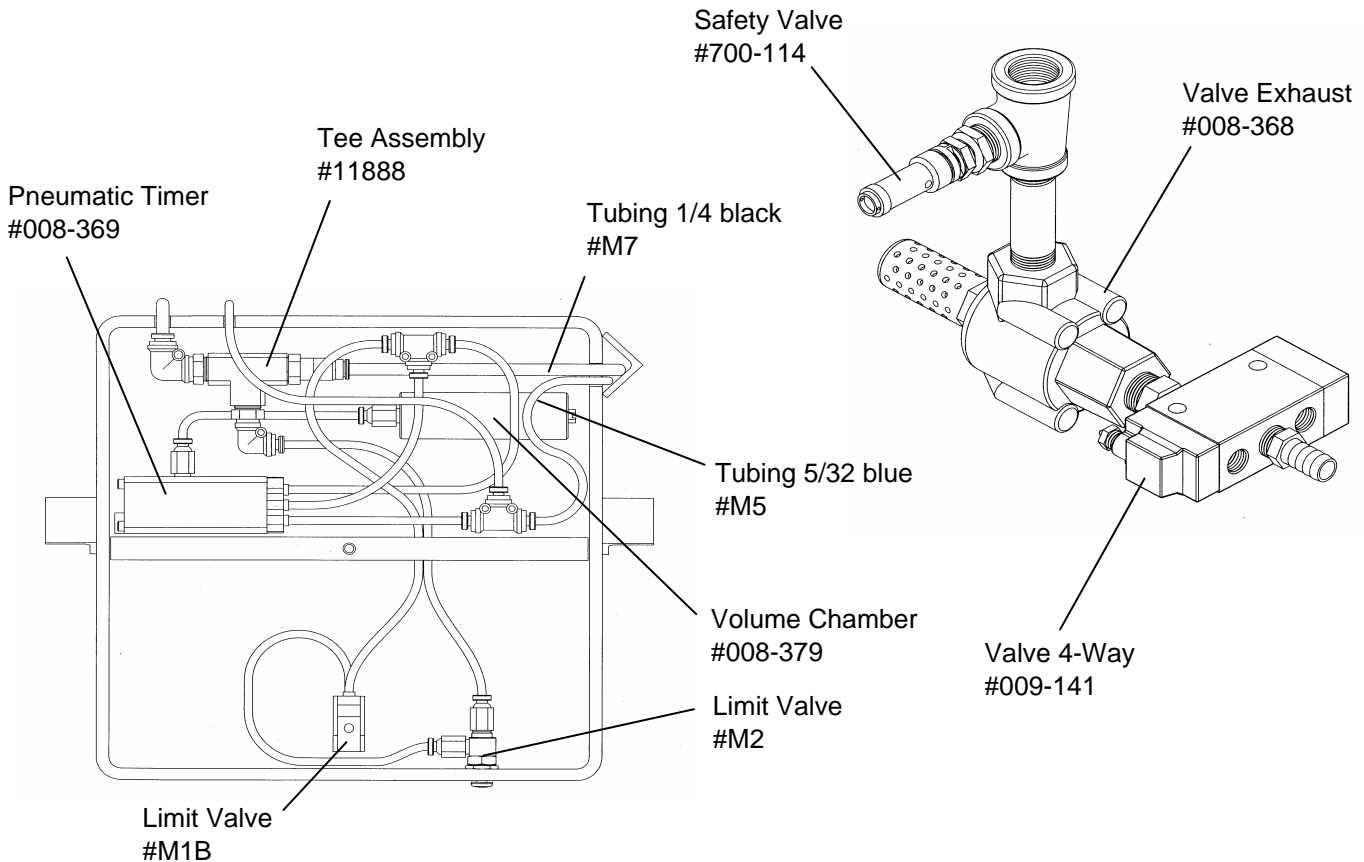

SERVICE PARTS

