

Model: HCR1

OWNERS MANUAL



INSTRUCTIONS

This manual contains important information concerning the installation and operation of the crusher listed above.
Read manual thoroughly and keep for future reference

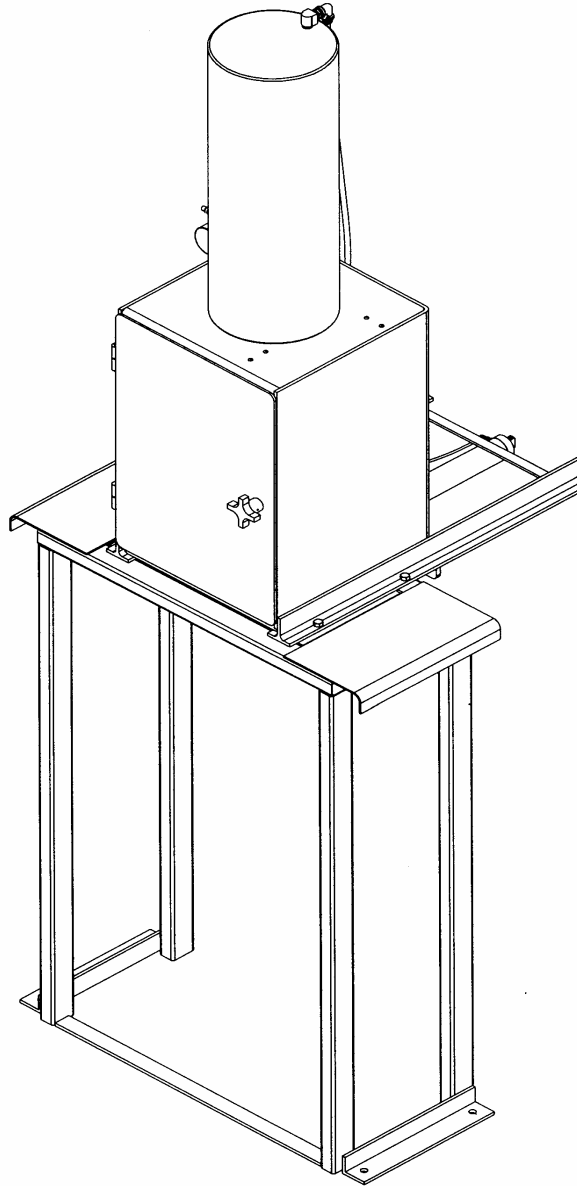

Herkules Equipment Corporation
248-960-7100

website: www.herkules.us

2760 Ridgeway Court
800-444-4351

e-mail: info@herkules.us

Walled Lake, MI 48390-1662 USA
Fax 248 960-7109

Table of Contents

Warnings	3
Model Information (List of models with descriptions and data)	4
Installation	5
Inspection	6
Operation	6
Maintenance	7
Repair	7
Drawings with part lists:	7-8

Warning Symbol



This symbol alerts you to the possibility of serious injury or death if you do not follow the instructions.

Caution Symbol



This symbol alerts you to the possibility of damage to or destruction of equipment if you do not follow the instructions.

Serial Number _____

Model Number _____

Purchase Date _____

Distributor _____



WARNING

FAILURE TO HEED THE FOLLOWING WARNINGS MAY RESULT IN PERSONAL INJURY AND/OR PROPERTY DAMAGE.

- 1 Herkules will not be held responsible for any personal injury and/or property damaged caused due to owner/operator failure to follow the warnings and cautions listed in this manual.
- 2 Read and understand all warnings, cautions and instructions before operating this equipment.
- 3 It is the owner/operators responsibility to maintain the legibility of all warning and instruction labels.
- 4 Do not alter or modify any part of this equipment.
- 5 Do not attempt to bypass the door/latch interlock system. The door interlock is provided for operator safety.
- 6 DO NOT open the door while the unit is operating. Always wait for the crusher to cycle completely.
- 7 Crush only intended matter for the crusher.
- 8 Always wear safety glasses when operating the crusher.
- 9 Always wear suitable industrial gloves when handling crushed objects to prevent injury.
- 10 Check equipment regularly for proper operation and repair or replace worn or damaged parts immediately.
- 11 Any crusher that appears to be damaged in any way, is badly worn or operates abnormally shall be removed from use until repairs are made. Use only manufacture's approved accessories and service parts. Contact a factory authorized service center for repairs.
- 12 DO NOT REMOVE THIS LABEL. REPLACE IF DAMAGED.

Model Information

SPECIFICATIONS

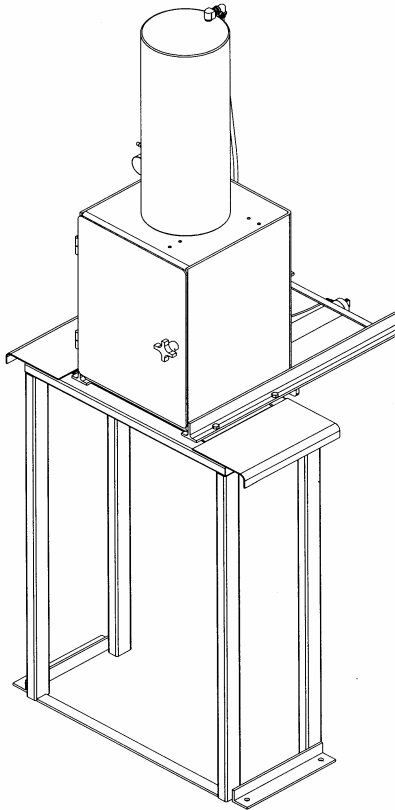

Maximum crushing pressure	3.75 tons
Can capacity	Four 1-gallon cans Seven 1-quart cans One 5-gallon can
Time to crush can	20 seconds
Overall width	33"
Overall height	91"
Overall depth	29"
Chamber width	14"
Chamber height	17.5"
Chamber depth	14"
Required air pressure	90-120 p.s.i.
Total weight	350 lbs.

DESCRIPTION

Model HCR1 is a production crusher capable of crushing four 1-gallon cans or seven 1-quart cans or one 5-gallon can. The stand accommodates a 55-gallon drum to collect crushed and ejected cans

The crusher provides the following features:

- Powerful 3.75 ton cylinder crushing plate assures the force necessary to do the job when crushing up to 7 quart cans.
- Operates with external air. No electric power is required.
- Safe double lock door protects operator.
- Lower slider plate automatically slides open at the end of the crushing cycle to eject cans into a disposal drum located under the stand.

OWNER/OPERATOR RESPONSIBILITY

It is the owner/operator responsibility to properly use and maintain this equipment.

The instructions and warnings contained in this manual shall be read and understood by the owner/operator prior to operating this equipment.

If an owner/operator does not understand English, the contents of this manual shall be explained in the owner/operator native language to assure the owner/operator comprehends.

It is the owner/operator responsibility to maintain the legibility of all warning and instruction labels.

The owner/operator shall retain this manual for future reference to important warnings, operating and maintenance instructions.

INSTALLATION

Installation consists of attaching the stabilizer feet to the stand, the stand to the crushing chamber, and connecting an external air supply with 90 to 120 p.s.i.

See Figure (1). Install the crusher as follows.

- A. Bolt stabilizer feet to the crusher stand using the four 3/8-16 x 3/4 bolts & washers.
- B. Using a hoist or Hi-Lo, set the crusher chamber on the stand with the upper crossbar facing the front of the unit.
- C. Bolt crusher chamber to stand using the remaining 3/8" hardware supplied.
- D. Connect the supplied pressure regulator/filter to the 3/8" valve located on the back of the crushing chamber.
- E. Connect the external air supply to the pressure regulator/filter.

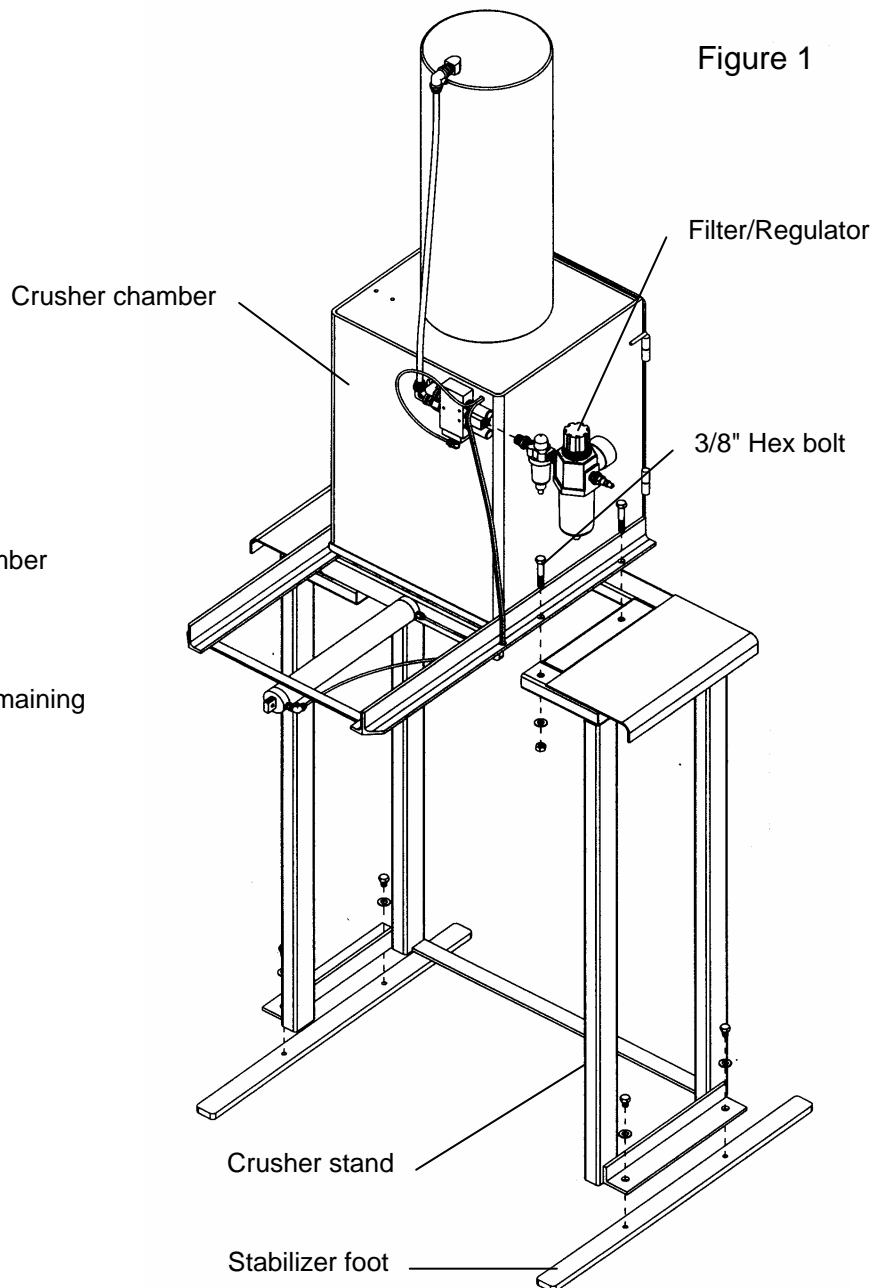

INSPECTION

Prior to operation a visual Inspection shall be made. Check crusher for leaks, worn or missing parts.

Any crusher that appears to be damaged in any way, is badly worn or operates abnormally shall be removed from use until repairs are made. Contact a factory authorized service center for repairs.

If over pressurizing of the equipment is believed to have occurred, contact a factory authorized service center for inspection of the crusher.

An annual inspection by a factory authorized service center is recommended.

OPERATION

Turn the external air supply on.

Verify the pressure gauge on the pressure regulator/filter reads between 100 and 120 p.s.i. Adjust the regulator as required.

NOTE:

If the external air supply is less than 100 p.s.i., the crusher will operate but the crushing performance is reduced.

Open door and place empty can(s) in center of chamber. See fig.2 for proper placement of cans in crusher.

Figure 2

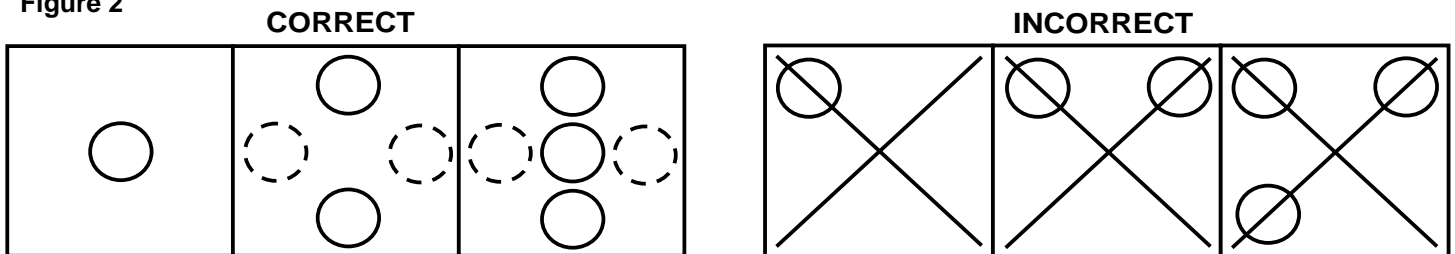

Close the door and latch it firmly.

The pneumatic piston will descend to crush the can(s). At the end of the crushing cycle (approx. 20 seconds) open the door to end the crushing cycle. This will trigger the automatic ejection plate. The crushed can(s) will fall from the chamber. Make sure and have a container underneath the crusher to catch the crushed can(s).

⚠ WARNING

The crushing mandrel may be still moving when the door is opened. Wait until the mandrel stops before placing hand in chamber.

IMPORTANT!! LEAVE THE DOOR AJAR WHEN NOT IN USE.

⚠ WARNING

A crushed can may have jagged metal edges. Use good industrial work gloves to protect the hands when handling a crushed can.

SAFETY INFORMATION

Read and understand all warnings, cautions and instructions before operating this equipment. Caution should be used when operating this equipment as personal injury and/or property damage can result from equipment misuse. Adequate personal protection is recommended to prevent splashing of fluids on the skin or in the eyes.

MAINTENANCE

Regularly check the pressure filter/regulator moisture trap for water. Drain as required.

Regularly clean the crusher chamber to remove any accumulated sludge, metal particles or any other debris that could affect the crusher operation.

Apply grease to door hinges on a regular basis to prevent the door from binding.

Apply motor oil to door latch pivot points on a regular basis to prevent latch from binding.

REPAIR

No service parts are available for this can crusher. Special tools and procedures are required for repair. If repair is required, contact Herkules Equipment Corporation Customer Service, (800-444-4351) for your nearest authorized service center.

AIR SCHEMATIC/SERVICE PARTS

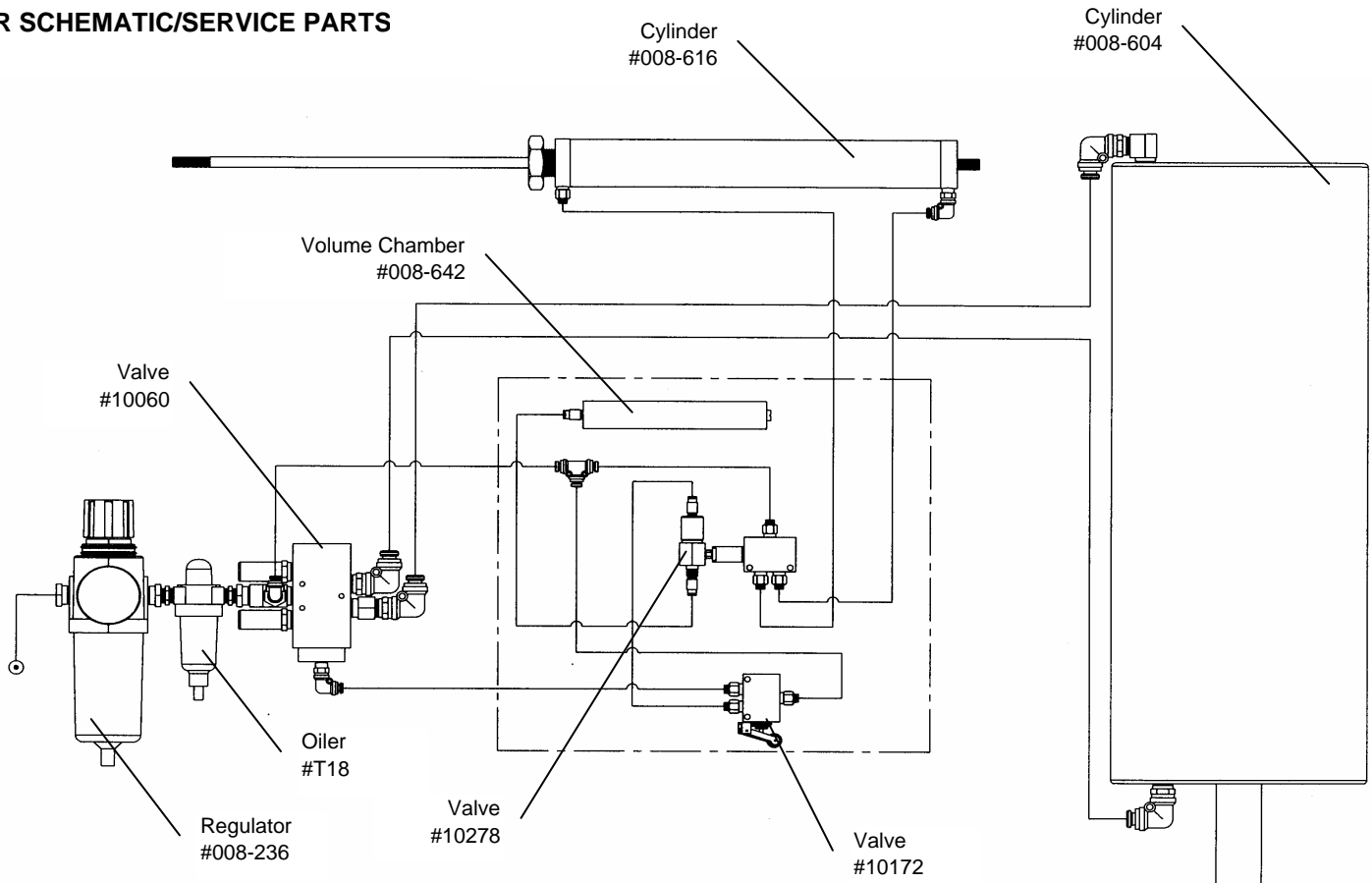

SERVICE PARTS

