

flexibility by design



Herkules Air-Bag™ technology

- Hydraulic-free - no hydraulic oils or fluids
- No electrical connections needed
- Uses existing central air supply
- No costly cylinders to maintain or replace



LOW PROFILE

In its lowered position, the Olympic Lift is about 4" high. The low profile can accommodate a wider range of ergonomically correct worker heights.

existing cart specifications

Using your cart specifications, Herkules can quickly build customized cart lifts and positioners.

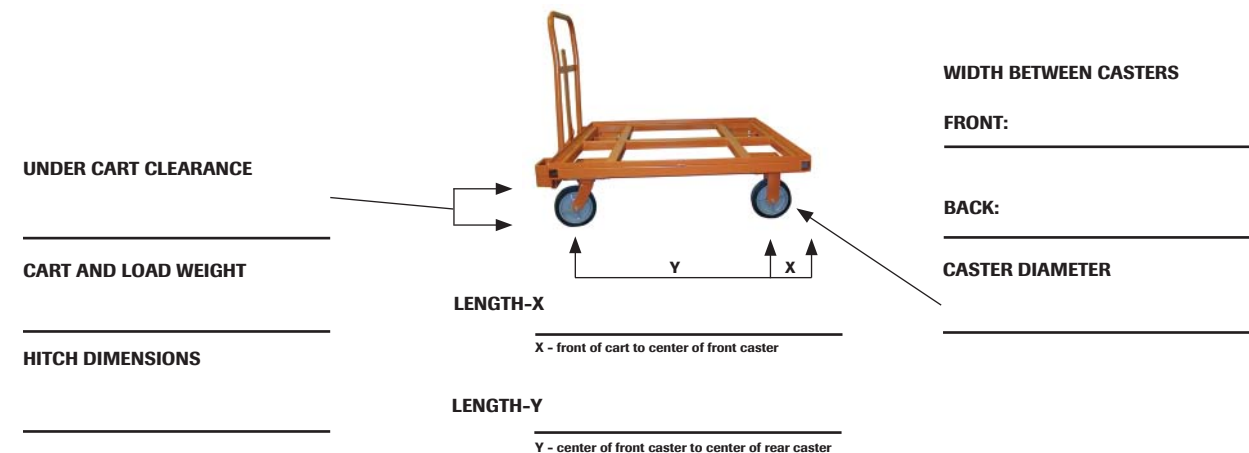

herkules equipment corporation

Herkules Equipment Corporation is the leading manufacturer of high capacity, air-operated lifts. For more than 25 years Herkules lifts have been recognized worldwide for lifting capacity, durability, flexibility and ease of use.

Lifts powered by Herkules proprietary Air-Bag™ technology are clean, environmentally friendly, and virtually maintenance free. Used in a variety of industrial and vehicle service applications, air bag lifts are hydraulic-free, requiring only a compressed air connection. The heavy duty air bags are built for rugged daily use, giving your facility a lifetime of trouble-free operation.

In manufacturing plants, vehicle service shops and government facilities, Herkules air-bag lifts surpass all others for lift capacity, low cost of operation and absence of potential environmental hazards.



industrial lift division • 2760 Ridgeway Ct. • Walled Lake, MI 48390 • toll free: 800.444.4351 • 248.960.7100 • fax 248.960.7109
email: info@herkules.us • www.herkules.us

L - 0034 published April 2005

Cart Lifts / Positioners



Industrial Lift Division



Cart Lift / Positioner Solutions

Flexibility by Design – Off the Shelf Pricing



MARKET LEADING FEATURES

- **Powered by Herkules Air-Bag™ technology** - Olympic lifts are efficient to use, clean, safe and virtually maintenance-free.
- **Low Profile** - Olympic lifts provide the lowest profile in the industry, accommodating low clearance carts, and providing a wider range of ergonomically correct worker heights.
- **High Capacity** - Herkules Air-Bag™ technology delivers enormous lifting capacity, capable of lifting virtually anything.
- **Direct 1-to-1 Lift Ratio** - The smooth lifting motion, powered by Herkules Air-Bag™ technology, eliminates stress on the scissors, reducing maintenance costs.
- **Easily Customized** - Cart positioners are designed and built using stock modules, 90% of the engineering is already completed.
- **Designed and Built to Your Cart Specifications** - Herkules will examine your existing cart inventory providing the exact cart positioner that you need.
- **Safe and Cost Efficient for Plant Operations** - Fork truck use is minimized, reducing energy and labor costs.
- **Creates Ideal Ergonomics for Operators** - Cart Positioners (lifts, rotating lifts, tilts and lift & tilts) will improve productivity and reduce injuries.



LIFT TOP CONFIGURATION
Top plate steel bars close the gap between the bottom of the cart and top of the lift when needed. Stop gussets or retaining plates stabilize the cart and position it on the lift.

CART TILT

SELECT THE OPTIMUM ANGLE FOR ULTIMATE EFFICIENCY

Special features can be added per customer specifications. A hitch ramp lifts and guides the cart's hitch, providing smooth loading of the cart. Steel side walls protect operators from pinch points, and guide cart alignment.



CUSTOM TOP PLATE
Custom top plate includes a burn out for securing the wheels of the cart for stabilization.

ROTATING CART LIFT

Provides easy access to material on all sides of the cart. Rotation bearing is located under the lift so rotating a cart is easy - there is no need to purchase expensive carts with rotation tops.

POST LIFT
Ball and screw lift provides a 1/4" low profile to easily load the cart - capacity of 3000 lbs. Air or electric operated with push button controls mounted on post or free-standing pedestal. Ideal for narrow carts.

CART LIFT AND TILT
Olympic Lift and Tilt has the lowest profile at 8.75". Tilt angle up to 45°. Tilt limit can be easily customized to exact customer specification. Safety skirting keeps debris out and provides protection from pinch points. Available in traditional vinyl or new polyethylene.



TOP PLATES
Top plates can be designed to accommodate many different sized carts - carts as narrow as 27" between casters.



ERGONOMIC POSITIONING
Position cart and contents in ideal ergonomic positioning so workers are more productive, and experience less back pain.

